

JET TENDER® 15

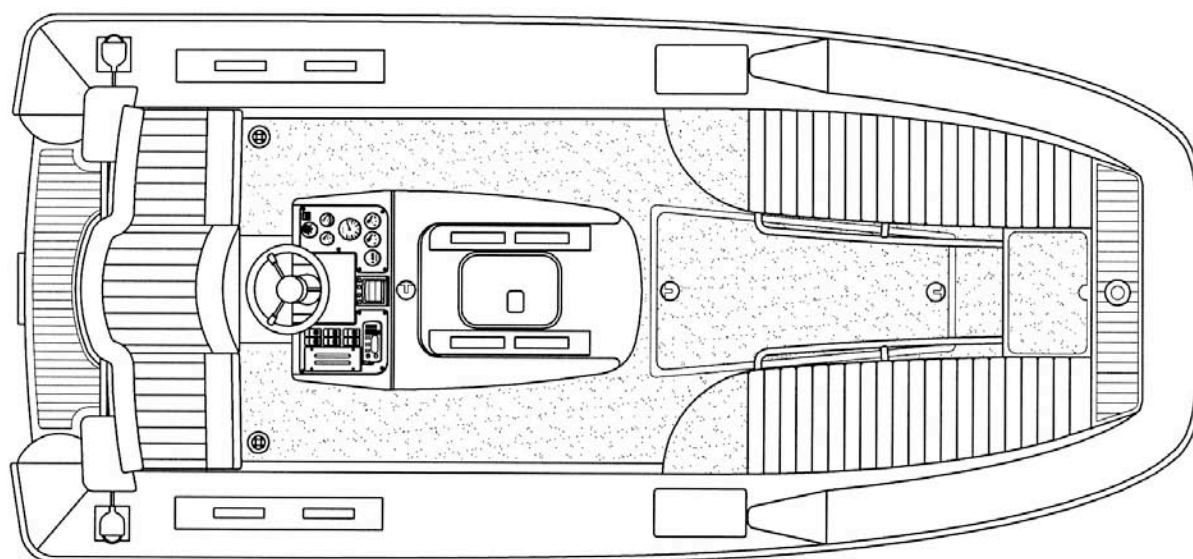
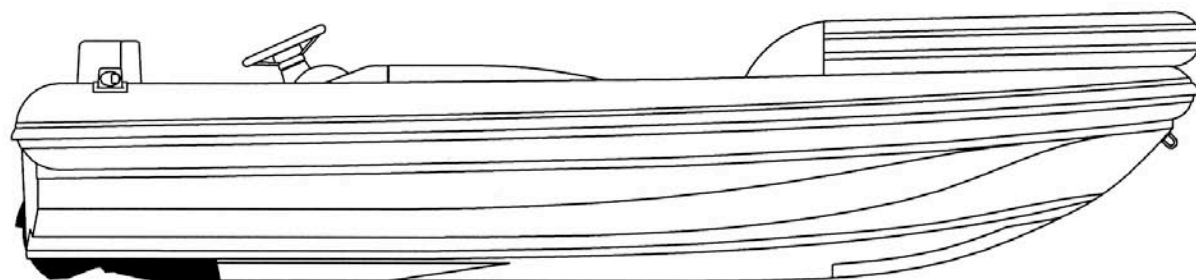

DIMENSIONS

Length o.a.:	4,45 m.
Beam max.:	2,03 m.
Height max. (with folded helm):	0,80 m.
Height max. (with B.I.S.S. inflated):	1,00 m.
Diameter inflatable tubes (at stern):	0,32 m.
Independent tube's compartments:	No. 5 + B.I.S.S.
Seat placements:	No. 7
Passengers capability (C.E. directive):	No. 7
Design category (C.E. directive):	C

STANDARD EQUIPMENT

Driving console with folding helm through an electric ram allowing also a personal set-up - hydraulic steering system with stainless steel steering wheel - instrument panel with ignition key, warning lights, engine instruments and fuel level gauge - Morse twin lever box for the mechanical/hydraulic control of the reversing deflector and for the mechanical control of the throttle - waterproof console cover - No. 1 permanently installed stainless steel fuel tank 62 l. capacity with fuel filler and vent - 12 V free maintenance hermetic battery - battery on/off switch - air intakes and vents - No. 2 electric bilge pumps - electric horn - handles - pump for inflatable tubes - integrated stern platform with teak shelf - stainless steel ladder with teak steps - No. 1 bow hook - ski-tow - kit for emergency repair for inflatable tubes - pair of paddles - deck courtesy lights - Castoldi water jet unit type "Jet 05" with Durethan impeller - handle for the control of the disconnecting clutch - knob for the control of the movable debris screen grid - No. 2 cushions for fore benches - cushion for transom seats with folding back - fore keel protection (replaceable) - recessed single point lifting hook - safety engine stop - B.I.S.S. (bow inflatable spray shield) - navigation lights (sides: green and red, stern: white 360° on plug-in pole).

DIESEL MOTORIZATION

- Yanmar type “4JH3-TE” - 75 HP
 - Yanmar type “4JH3-HTE” - 100 HP
 - Yanmar type “4JH3-DTE” - 125 HP
-

OPTIONAL EQUIPMENT

- Anchor, Danforth model, Kg, 5, made of polished stainless steel, with chain 2,00 m. long and rope 15,00 m. long
- Antiskid stripes on tube’s walking area
- Bimini top (transom)
- Deck shower with pressurised fresh water system and 30 lt. water tank (Kg. 7.6)
- Kit of engine’s spare parts
- Kit of water jet unit’s spare parts
- Lifting eyes No. 4
- MCA Approval - special version
- Mooring cover
- No. 2 bow/side towing eyes
- No. 2 writings “**TENDER TO....**” made on Hypalon-Neoprene coated fabric vulkanized on both sides
- Plug 12 V for battery charger
- Plug 12 V plus 110/220 V portable battery charger
- Portable watertight search-light
- Raymarine ” ST 60 Tridata” (Depth/speed/Log)
- Spray dodger
- Teak decking (8 mm, solid, Kg. 12)
- VHF, Icom type, waterproof, with aerial and with European, international and USA frequencies

* Other electronical instruments available on request *