

# JET TENDER® 14

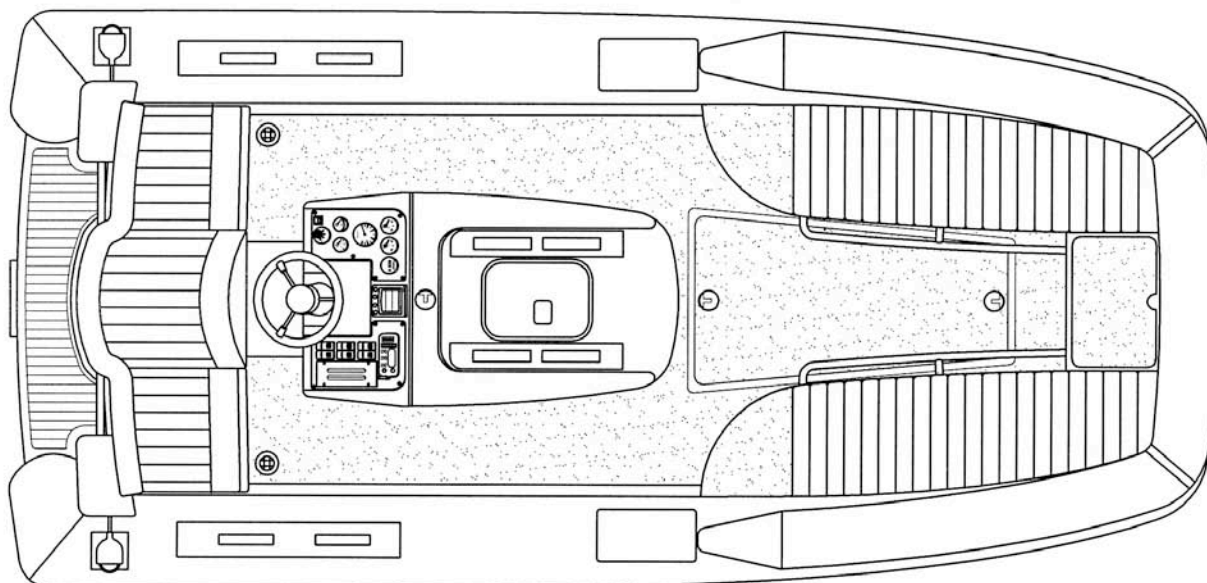
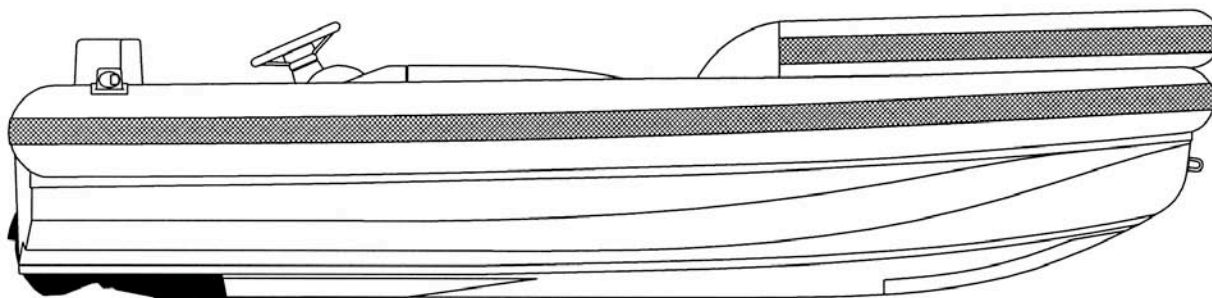

## ***DIMENSIONS***

Length o.a.:	4,20 m.
Beam max.:	2,00 m.
Height max. (with folded helm):	0,80 m.
Height max. (with B.I.S.S., inflated):	1,00 m.
Diameter inflatable tubes (at stern):	0,32 m.
Independent tube's compartments:	No. 5 + B.I.S.S.
Seat placements:	No. 7
Passengers capability (C.E. directive):	No. 7
Design category (C.E. directive):	C

## ***STANDARD EQUIPMENT***

Driving console with folding helm through an electric ram allowing also a personal set-up - hydraulic steering system with stainless steel steering wheel - instrument panel with ignition key, warning lights, engine instruments and fuel level gauge - Morse twin lever box for the mechanical/hydraulic control of the reversing deflector and for the mechanical control of the throttle - waterproof console cover - No. 1 permanently installed stainless steel fuel tank 62 l. capacity with fuel filler and vent - 12 V free maintenance hermetic battery - battery on/off switch - air intakes and vents - No. 2 electric bilge pumps - electric horn - handles - pump for inflatable tubes - integrated stern platform with teak shelf - stainless steel ladder with teak steps - No. 1 bow hook - ski-tow - kit for emergency repair for inflatable tubes - pair of paddles - deck courtesy lights - Castoldi water jet unit type "Jet 05" with Durethan impeller - handle for the control of the disconnecting clutch - knob for the control of the movable debris screen grid - No. 2 cushions for fore benches - cushion for transom seats with folding back - fore keel protection (replaceable) - recessed single point lifting hook - safety engine stop - B.I.S.S. (bow inflatable spray shield) - navigation lights (sides: green and red, stern: white 360° on plug-in pole).

***DIESEL MOTORIZATION***

Yanmar type “4JH3-TE” - 75 HP .....

Yanmar type “4JH3-HTE” - 100 HP .....

Yanmar type “4JH3-DTE” - 125 HP .....

---

***OPTIONAL EQUIPMENT***

- Anchor, Danforth model, Kg, 5, made of polished stainless steel, with chain 2,00 m. long and rope 15,00 m. long .....
- Antiskid stripes on tube’s walking area .....
- Bimini top (transom) .....
- Deck shower with pressurised fresh water system and 30 lt. water tank (Kg. 7,6) .....
- Kit of engine’s spare parts .....
- Kit of water jet unit’s spare parts .....
- Lifting eyes No. 4 .....
- MCA Approval - special version .....
- Mooring cover .....
- No. 2 bow/side towing eyes .....
- No. 2 writings “**TENDER TO....**” made on Hypalon-Neoprene coated fabric vulkanized on both sides .....
- Plug 12 V for battery charger .....
- Plug 12 V plus 110/220 V portable battery charger .....
- Portable watertight search-light .....
- Raymarine ”ST 60 Tridata” (Depth/speed/Log) .....
- Spray dodger .....
- Teak decking (8 mm, solid, Kg. 12) .....
- VHF, Icom type, waterproof, with aerial and with European , international and USA frequencies .....

\* Other electrical instruments available on request \*